

Yet another
flow chart:

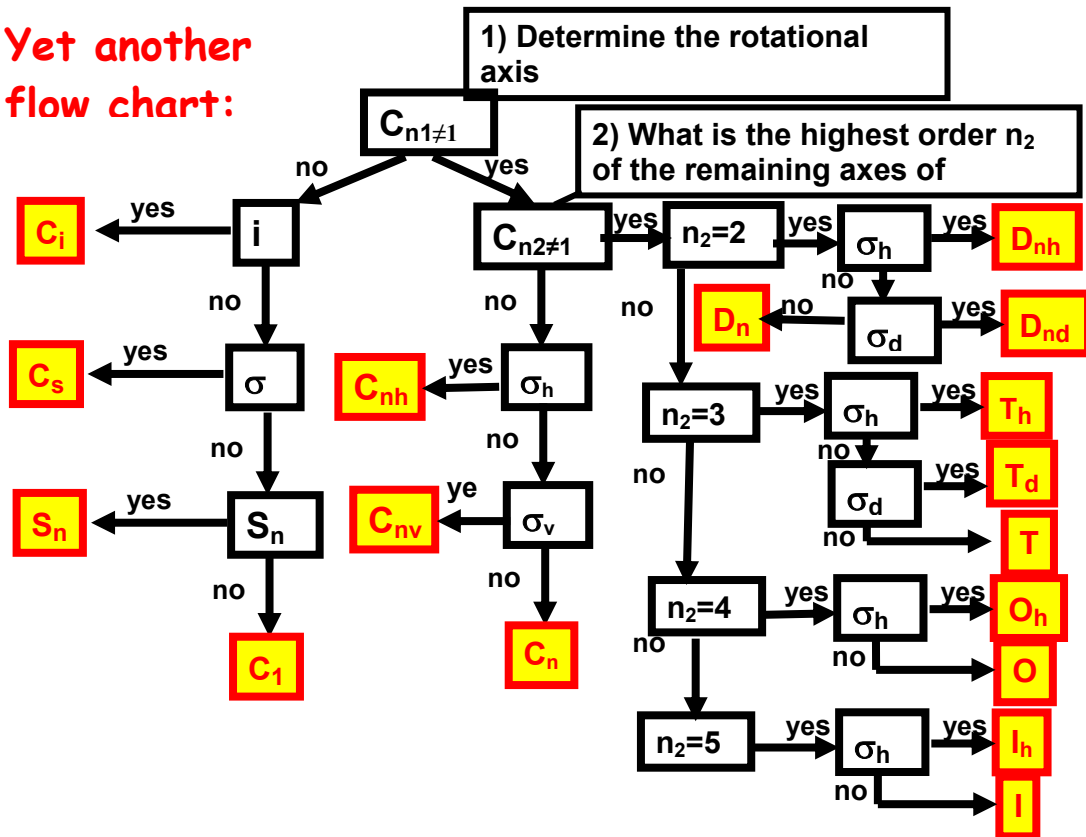

Fig. 2.7c Decision Tree III