

# Learning Support Tools for Developing Spatial Abilities in Engineering Design

**Manuel Contero**

University of Valencia

**Pedro Company**

Jaume I University

**José Luis Saorin**

La Laguna University

**Ferran Naya**

Technical University of Valencia

## Introduction

There are many references in current literature that justify the role of spatial reasoning as a fundamental skill for engineers. Until the 90's, in Europe, this skill was introduced indirectly in the curricula as the "ability" required for both understanding and solving Descriptive Geometry problems, and reading and sketching technical drawings. Learning to use a 2D CAD package was offered usually as a complement to these classical contents. Progressively 3D modeling was incorporated in order to support the virtual prototype concept, where the 3D geometric models built by the CAD applications are used by downstream application as CAM and CAE systems. Nevertheless 3D modeling was not a declared objective on its own. So, the engineering graphics curricula added the 3D model creation as an appendix, which was or was not included, depending on the timetable requirements and hardware limitations, but did not alter the core of such curricula. We can conclude that during the last decades we appreciate some changes in the contents of the Engineering Graphics discipline, but barring some exceptions, spatial abilities are still considered as a secondary goal that simply is achieved through the learning of other concepts.

Now in the European context, important changes are being introduced as a consequence of the construction of a European Higher Education and Research Area. Thus involving a shift in the education paradigm from a teacher-centered to a student-centered model. Two points of the Bologna Declaration (one of the key documents of this initiative) are specially related with it. The first one is the promotion of the necessary European dimensions in higher education, particularly with regards to curricular development, inter-institutional co-operation, mobility schemes and integrated programmes of study, training and research. The second element is the establishment of a common system of "credits" for promoting the most widespread student mobility. Besides, we can note this change of focus in higher education in the proper description of the "European Credit Transfer and Accumulation System" (ECTS), that is defined as a student-centered system based on the student workload required to achieve the objectives of a

programme, objectives preferably specified in terms of the learning outcomes and competences to be acquired.

These changes initiate a critical analysis of many engineering courses' subjects. In our case, as teachers of "Engineering Graphics", this change enforces us to make explicit some objectives that previously were achieved in an indirect form. This is the case of visual and spatial reasoning skills. In the new context, visual reasoning is to be considered, in terms of the learning outcomes and competences, as a capital aspect of future engineers' education. CAD tools and, particularly the different "views" of CAD models used for engineering purposes, cannot be once more considered a secondary learning ability. On the other hand, the need to include more and more knowledge and abilities in the already dense curricula of future engineers demands a great improvement of curricula efficiency. In short, spatial reasoning, understood as a core competence for future engineers, does not only remain but it does gain relevance in current and future engineers' curricula. But, at the same time, it must be introduced in a very efficient way.

In this context, both our previous experience in teaching traditional Engineering Graphics and our research in both on-line and batch computer-aided generation of 3D models from 2D freehand sketches [0,1], has led us to develop some "special" learning support tools for developing spatial abilities in engineering design. We have tried to provide our students with attractive applications that combine and develop three important elements for the future engineer: spatial visualization, freehand sketching and normalized view generation. Although it is recommended to use Tablet-PCs or at least graphic tablets to provide an experience similar to real paper, these applications can be run using standard PCs too.

These tools combined with proper exercises are showing promising results in a pilot study that is being realized in some Spanish universities. Two well-known tests for evaluating spatial abilities: Mental Rotation Test (MRT) and the Differential Aptitude Test - Spatial Relations subset (DAT-SR) have been used to validate the experience from a psychological point of view.

## **The European Higher Education and Research Area: A New Learning Paradigm**

The Bologna Declaration was signed in 1999 by 29 European countries to improve the convergence of their higher education systems. The Declaration reflects a search for a common European answer to common European problems: challenges related to the growth and diversification of higher education, the employability of graduates, the shortage of skills in key areas, the expansion of private and transnational education, etc.

The Bologna process is not aimed at "standardization" or "uniformization" of European higher education, but at creating compatible systems and common action. The Bologna Declaration [4] involves six actions relating to: 1) a system of academic grades which are easy to read and compare; 2) a system essentially based on two cycles: a first cycle geared to the employment market and lasting at least three years and a second cycle (Master) conditional upon the completion of the first cycle; 3) a system of accumulation and transfer of credits; 4) mobility of students, teachers and researchers; 5) cooperation with regard to quality assurance; 6) the European dimension of higher education.

The third objective (i.e. a system of accumulation and transfer of credits) is known as the European Credit Transfer System (ECTS) that already proved to be successful under Socrates-Erasmus program<sup>1</sup> [5]. It is described in [6] as a “limited and provisional set of prescriptions to encourage student exchange within the European Union”. Credit is given for successfully completing courses in another country (ie, the 'host' institution), which count towards an award where the student is registered (ie, the 'home' institution). Thus, credit is awarded by the host institution but is transferred to and recognized by the home institution. Hence, ECTS implementation make it appear a real need to harmonize the studies in different universities and countries. First of all, credits were assigned according to workload. And an homogenization of workloads was enforced in the basis of 60 credits encompassing one year of study, 30 credits for six months (a semester) and 20 credits for a term (a trimester). However, whether the credit system should be based on workload or competencies is still being questioned. It has been said (see [7]) that certainly a European credit system should be developed as an extension of ECTS, but that a reflection by subject area at European level is required too. In other words, an agreement exists that a workload system is not enough and that other type of descriptors of the learning outcomes sanctioned by the credits is needed. It is, however, difficult to agree on such descriptors at an abstract level. Besides, it has been said above that the need to include more and more knowledge and abilities in the already dense curricula of future engineers demands a great improvement of curricula efficiency.

In other words, in addition to shift in the education paradigm from a teacher-centered to a student-centered model, it is time to initiate a critical analysis of many engineering courses' subjects. In particular, we believe teachers of “Engineering Graphics” should put the emphasis in spatial reasoning, since we do consider it to be a core competence for future engineers, which must gain relevance in future engineers' curricula. But, at the same time, it must be introduced in a very efficient way, because of the workload constraints imposed (or made apparent) by ECTS system.

## The Importance of Spatial Abilities in Engineering

Spatial reasoning was a well-known main engineering skill in the past, when geometrical design was carried out through engineering graphics in the so-called “design-by-drawing” method. And its importance has increased dramatically since the end of the 80's, when 3D CAD applications opened the door to a new “design-by-virtual models” paradigm that is progressively replacing design-by-drawing.

Yet, this importance is not always translated into explicit consideration in syllabuses, textbooks and the like. In the 2003-2004 edition of the French classic “Guide du dessinateur industriel” [8], A. Chevalier includes a chapter on “Modélisation 3D”, although classical contents still dominate

---

1 ERASMUS action is targeted at higher education institutions and their students and staff in all 25 Member States of the European Union, the three countries of the European Economic Area (Iceland, Liechtenstein and Norway), and the three candidate countries (Bulgaria, Romania and Turkey). Currently 2199 higher education institutions are participating in ERASMUS. Since the creation of ERASMUS in 1987, 1.2 million students have benefited of an ERASMUS study period abroad. The ERASMUS budget for the year 2004 is more than \$ 240 million.

the structure of the book; as can be seen, for instance, when realizing that subjects like isometric or cavalier perspectives are still included together with perspectives of a 3D model. One of the most referenced books in Italian engineering schools [9,10], was first launched in 1996-97 and included a more or less classic table of contents and complementary references to AutoCAD as accompanying software. On the contrary, the 2004 edition of volume 2 (the new edition of volume 1 is announced to appear in 2005) is linked to a full-featured version of Solidworks 2004 student edition. A similar thing happened to the successful Spanish book "Dibujo industrial" [11], which is still "complemented" by a separate book [12] covering CAD through AutoCAD. To be noticed that CAD covering is not limited to 2D drafting, but includes CSG 3D models and the like. In sum, leading European textbooks on engineering graphics are being progressively updated to teach 2D and, in some cases 3D CAD, but the core of their contents still remains unchanged. Multiview drawings, descriptive geometry and similar subjects of the design-by-drawing paradigm are still dominant, and the subjects of design-by-virtual-prototypes paradigm are, at best, just complements.

A similar thing is supposed to happen in the USA, where leading textbooks, like the successive versions of Bertoline's et al. book [13] (which claims to "cover drawing techniques from both a contemporary CAD-oriented perspective and a traditional perspective") still coexist with contemporary descriptive geometry textbooks [14].

However, spatial vision, or acquisition of developed sense of spatial reasoning, is clearly seen as the most endeavoring part of engineering graphics instruction. Ferguson [15] defines engineering drawings as a means by which a vision in one person's mind might be conveyed by material means –drawings– across space and time to another person's mind. Furthermore, in his opinion "... the best way to learn how to read drawings, and probably the only fully effective way, is to learn how to make drawings". In a recent special issue on "CAD education" (Computer-Aided Design vol. 36 no. 14), Field [16] finished with a "... call for all CAD-users to obtain a higher developed sense of spatial reasoning", since "... everyone using CAD needs a highly developed sense of spatial reasoning". This is true as far as design is done essentially in the mind, and drawings are pictorial extensions of the mind.

In sum, development of visualization skills is one important objective of engineering graphics basic courses. This learning outcome can be described as the ability to picture three-dimensional shapes in the mind's eye. Learning to "pick and click" on a specific 3D CAD software is generally seen as the only path to acquire such skill. Besides, training 3D CAD is a desirable procedural learning outcome too. Hence, this is the paradigm that seems to dominate the current trends in modern engineering graphics courses.

However, conceptual designs are usually conveyed through sketches, not models. Hence, acquiring spatial reasoning through a sketching user interface, which, in turn, automatically generate 3D models, could improve the efficiency of the process at the same time that could help in moving to a new paradigm of "design-by-sketch-modeling".

## **Approaches to Improving Spatial Abilities**

As noted previously the development of spatial abilities has been achieved traditionally in an indirect way by means of the classical Descriptive Geometry and Engineering Drawing basic

courses. Some international experiences confirm [18] this assertion using several standardized tests as:

- The Mental Rotation Test (MRT) [19],
- The Mental Cutting Test (MCT) [20],
- The Differential Aptitude Test: Space Relations (DAT:SR) [21]

Spatial abilities are determinant in two key operations that designers, engineers and many other professions need to perform: capability for blueprint reading where a 3D mental representation has to be built from orthographic projections, and the reciprocal skill, deriving multiview drawings from real or imaginary 3D objects. Duesbury and O'Neil [22] have demonstrated that these abilities can be improved through practice that allows the learner to see the relationship between the 2D and 3D features of objects. In their study they used the commercial CAD tool Autocad to manipulate 3D wireframe representations. Devon et al. [23] performed another study analyzing the benefits reported by a 3D solid modeling system versus a 3-D wireframe system. They concluded that solid modeling enhances spatial visualization skills more than wireframe CAD or graphics taught in a traditional way.

Sketching and drawing are one of the most frequently used activities for improving spatial abilities. Also, we can find in the literature, several studies that have analyzed the impact of these activities. Potter and Van der Merwe [24] have conducted an instructional intervention over a 20-year period that has demonstrated that spatial ability influences academic performance in engineering, and can be increased through instruction focused on using perception and mental imagery in three-dimensional representation. Students identified as having weaknesses in three-dimensional perception were provided with additional remedial activities involving modeling, copying, sketching and drawing. Alias et al. [25] have reported that spatial visualization ability of civil engineering students can be improved through spatial activities consisting primarily of object manipulations and free hand sketching

JavaScript web-based games [26] and interactive multimedia technologies [27] can also be used to better communicate spatially based engineering concepts to students. Learning through games has shown to be both attractive and effective ways of developing spatial abilities. Nowadays, these technologies can be easily implemented and disseminated using Internet, providing resources to students with weaknesses in these fields.

The last block of applications we are going to comment on is instructional software that is built from scratch to help students to improve their spatial reasoning and 3-D visualization skills. Mengshoel et al. [28, 29] have developed the Visual Reasoning Tutor (VRT), an instructional system composed by three modules: the "Visual Sweeper", the "Visual Teacher" and a User Interface module. This system exploits the missing view problem as a mechanism to develop the visual reasoning abilities of students. In missing view problems, students create 3D solid objects from two 2D projections by applying operations inverse to orthographic projection. Osborn and Agogino [30] developed an interface for software that provides an environment which allows the user to interactively explore any arbitrary position of a given object using direct manipulation. Also, it provides the capability to demonstrate standard orthographic and axonometric views with animation, and uses a cutting-plane mode based on the metaphor of a "pool of water" in which the object is partially submerged.

## Adapting Research Applications to an Educational Context

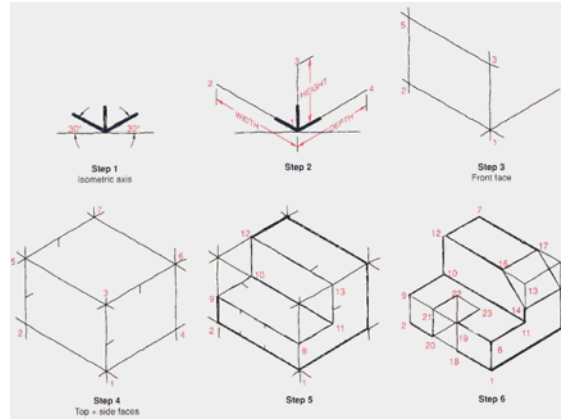
As noted by J.H. Mathewson [17], our teaching strategies must compete with very dynamic and colorful communications media for the attention of students. Nowadays, most students are accustomed to use a large list of technological gadgets such as cell phones, MP3 players, hand held consoles and so on. This supposes a serious handicap if we rest only on traditional sketching a drawing exercises for developing visual abilities in our students. Studies have shown that positive attitudes towards prescribed learning activities facilitate the achievement of the desired learning outcomes. Alias et al. [31] indicate that any attempt to improve spatial visualization skills in engineering students through sketching and drawing has to consider the influence of student's views of sketching and drawing. They emphasize the importance of transmitting to the students the idea that sketching and drawing plays an important role as a communication and reasoning tool in engineering.

We think that both an attractiveness and efficiency goals can be accomplished adapting our research in on-line computer-aided generation of 3D models from 2D freehand sketches [1,2]. Our experience with students is that they show a very positive reaction from interacting with a Tablet-PC, making a freehand sketch and manipulating the 3D model that is "magically" provided by the application. This solves a difficult question: generating a positive attitude towards the sketching activity. The other aspect, efficiency, is achieved combining in a single application three key elements for the future engineer: spatial visualization, freehand sketching and normalized view generation.

The first application we are going to introduce is eREFER. It corresponds to an educational version of a research tool called REFER. Full details about it can be consulted in [2]. Here we will summarize its main features. The application provides the user with a "virtual pencil" that is used for freehand sketching on a sheet of "virtual paper". The drawing that the user introduces is a pseudo-axonometric representation of a polyhedral shape. We chose a pictorial-type representation because the aim is to foster the student's capacity for spatial vision and it is commonly accepted that orthographic parallel projections are more suited to measuring than to seeing. The application only accepts polyhedral models that satisfy some geometric restrictions, very limited compared with commercial CAD applications, but it has proved effective for training freshman engineers. When the student has finished his/her sketch, pushing a button, the system automatically builds a 3D model that matches with the previous sketch, and the user can then change the point of view, generate a shaded representation or observe the normalized orthographic projections of the object.

A second application called eCIGRO (educational version of a research tool called CIGRO [3]) provides an incremental sketch based modeling environment. This is the main difference with eREFER, where the 3D model is built when the user has finished the sketch. In eCIGRO, the user can sketch objects of similar shapes as in eREFER but using a reduced instruction set calligraphic interface which is very easy to learn. The interface is practically absent, because the idea is to provide an "augmented" paper to the user. Students draw lines on an axonometric projection, which are automatically beautified and connected to existing elements of the drawing. Such line drawings are converted into a three-dimensional model in real time through a reconstruction process based on an axonometric inflation method, providing a smooth switch between 2D sketching and 3D view visualization. The user can switch the point of view and

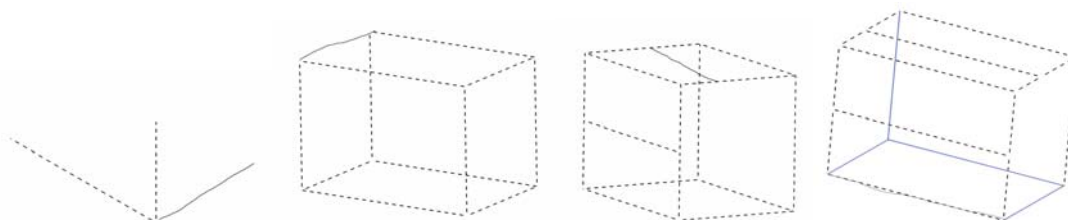
continue his sketch. Shaded representations and automatic normalized orthographic projections are provided by the system.

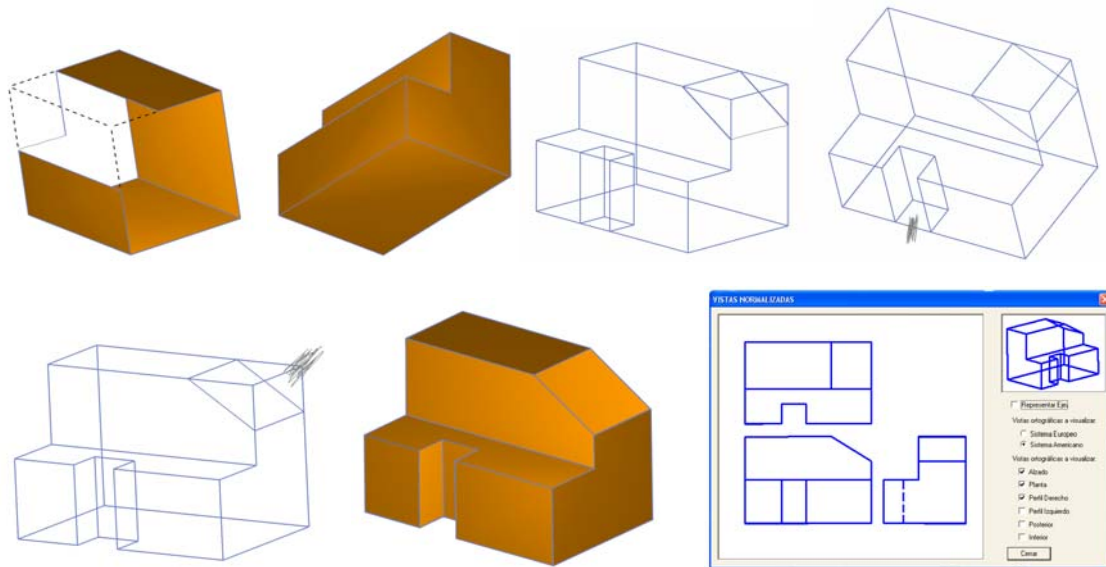


**Fig. 1. Example from Bertoline's book**

Sketching methodology (see Fig. 2 for a complete example) supported by eCIGRO follows the typical construction steps that are employed by engineers for making technical sketches [13]. This is an important point: students don't need to learn any special sketching methodology or program commands, they can apply the rules they have learned previously: beginning by defining the axonometric axis, then blocking in the object and the last step is adding details (Fig. 1 represents an example extracted from Bertoline's book [13], it is interesting to note that is not necessary indicate the three main directions explicitly, user can proceed directly with step 3 in Fig. 1, and the system detects automatically the main axis). As we can see in Fig. 1 line width and pressure is frequently employed to differentiate auxiliary and final sketch lines. Auxiliary lines serve to define main object dimensions and as a guide to define the other sketch elements. This working methodology is supported by two drawing gestures in eCIGRO: "new edge" and "new auxiliary edge". Our application takes into account the pressure made on the pencil by the user. In this way it distinguishes auxiliary constructions from real geometry lines, by applying a pressure level threshold (configured by user). Auxiliary strokes serve as references (using automated snaps) for the intended model geometry strokes.

The third supported gesture is "remove edge" (auxiliary or not) that is represented by a scratching stroke. It allows not only to correct mistakes but also to draw more complicated shapes from "simpler" forms (as represented in step 6 in Fig. 1). Users can construct shapes by either adding new edges or removing existing ones. The interface cooperates with the user by not requiring valid models to be present at all times. It rather allows geometric models which are consistent only at the face level.





**Fig. 2. Snapshots of interactive input sequence.**

If user draws making low pressure, black color is used to represent raw strokes. Then they are beautified in black dashed auxiliary lines. If user draws making high pressure, gray color is used to represent raw strokes before processing, and then they are beautified in blue lines, representing real geometry.

Before proceeding with the 3D reconstruction a preliminary “2D reconstruction” or “beautification” stage is performed to adjust input sketch in order to provide an adequate database for the axonometric inflation engine. As the user sketches a line the application adjusts it using the following drawing aids: automatic line slope adjustment, vertex point snap and vertex on line snap. The first drawing aid consists of checking whether the new line is parallel to any of the principal axes of the sketch or other line by considering a slope tolerance. In such case, one or both endpoints are adjusted so that the line results precisely parallel. The second analysis looks for new vertices proximity to previous ones, taking into account a vertex proximity tolerance. If new vertices fall into the tolerance region of previous vertices then they are snapped to the closest previous vertex. For endpoints of new lines which do not lie close to previous vertices, the system analyzes whether they are close to an existing edge, taking into account a given edge proximity tolerance. If several edges match this criterion, then the edge that lies closest to the given endpoint is selected. Snap tolerances exist to provide control to soften the beautification action.

At the end, all this automatic beautification process means that the user has only to think on sketching. The “low level” details are covered by the system. Of this way, the typical menus and buttons are reduced to a minimum. This, practically, means not wasting any time in learning to use the sketching tool.

## Some Preliminary Results

A preliminary essay is now being performed at La Laguna University (Tenerife, Canary Islands, Spain) in order to prepare an extensive study, to be carried out during the academic year 2005-06, to analyze the use of different learning approaches to develop visual abilities in engineering freshman students.

This experience is based on using eCIGRO as the learning tool for a remedial course that has been designed to provide support for those students with weaknesses in this field. Our main hypothesis is that an intensive remedial course (6 hours in our case) can compensate previous deficiencies and bring them to an acceptable level in visualization tasks, avoiding these students giving up the subject. Taking into account that motivation is very important for this group of students, and that many of them have no previous exposure to CAD applications, eCIGRO with its minimal interface, is a good candidate to offer this students an attractive learning environment.

Courses	Pre-Test Score (Std. Dev.)				Post-Test Score (Std. Dev.)			
	MRT		DAT-SR		MRT		DAT-SR	
	M	F	M	F	M	F	M	F
Electronic Engineering	17,17 (8,00) <i>n</i> =60	14,10 (7,03) <i>n</i> =10	43,57 (10,69) <i>n</i> =60	43,50 (11,24) <i>n</i> =10	25,00 (8,50) <i>n</i> =41	20,75 (8,28) <i>n</i> =8	50,80 (7,68) <i>n</i> =41	48,88 (8,34) <i>n</i> =8
Civil Engineering	15,18 (8,67) <i>n</i> =33	10,18 (5,41) <i>n</i> =25	40,39 (10,92) <i>n</i> =33	36,22 (10,93) <i>n</i> =25	25,62 (7,41) <i>n</i> =13	20,13 (10,06) <i>n</i> =8	49,85 (5,34) <i>n</i> =13	47,75 (8,99) <i>n</i> =8
Chemical Engineering	17,50 (7,97) <i>n</i> =12	10,50 (5,15) <i>n</i> =10	45,00 (10,30) <i>n</i> =12	39,90 (7,71) <i>n</i> =10	29,00 (8,47) <i>n</i> =9	19,71 (7,65) <i>n</i> =7	50,67 (9,27) <i>n</i> =9	51,86 (4,60) <i>n</i> =7

**Table 1. Results from pre-test and post-test where *n* represents the number of students**

We selected the Mental Rotation Test (MRT) and the Spatial Relations subset of the Differential Aptitude Test (DAT-SR) to detect those students with poorer spatial abilities, and to evaluate the outcomes of both the remedial course and the engineering graphics subjects offered in the first semester of academic year 2004-05. 150 students were "pre-tested", achieving a mean score of 15.05 (std. dev. 7.88) in MRT and 41.53 (std. dev. 10.82) in DAT-SR. At the end of the semester students were tested again. In this case 86 students participated in the post-test getting a mean score of 24.23 (std. dev. 8.65) in MRT and 50.36 (std. dev. 7.40) in DAT-SR. Table 1 presents the distribution of these students according to gender and course.

20 students with low test scores were selected for attending a six-hour remedial course. The mean MRT score for these students was 7.85 and 33.00 for DAT-SR. The remedial course was arranged in three two-hour sessions. Its main goal was to improve the spatial skills of the students till the minimum level required to follow their corresponding engineering graphics course. They were run during the first week of the semester, and the lecture contents were rearranged to prevent any similitude with tests. Once the remedial course was finished, the

students were tested again (“post-tested”) using the same type of tests as before (MRT and DAT-SR). Remedial course was organized around exercises to be solved with the eCIGRO application. Students had A6 graphics tablets (Wacom Volito) available for sketch input. In table 2 we show the pre and post scores obtained by students.

MRT		DAT-SR	
All students initial mean score: 15.05		All students initial mean score: 41.53	
Pre-Test (Std. Dev.)	Post-Test (Std. Dev.)	Pre-Test (Std. Dev.)	Post-Test (Std. Dev.)
7.85 (3.56)	12.05 (5,33)	33.00 (6.26)	40.40 (8.92)

**Table 2. Results from pre-test and post-test for remedial course**

For the statistical analysis we used a Student’s  $t$  test, taking as the null hypothesis ( $H_0$ ) that abilities of spatial visualization mean values have not varied after the remedial course has taken place. The  $t$ -Student for paired series was applied and  $p$  values representing the probability of the hypothesis being true were obtained. We obtained for MRT  $p = 5.05E-4 < 0.01$  and for DAT-SR  $p = 2.18E-5 < 0.01$ , hence the null hypothesis is rejected, and we can conclude, with a level of significance higher than 99% that the group under study did experiment a positive variation.

Other interesting aspect of this experience can be deduced from analyzing data in Table 1. There were significant gender differences on the MRT test, with  $p < 0.01$  in both pre and post tests. The behavior is different for DAT-SR, where we find significant differences for the pre-test with  $p < 0.05$ , but not for the post-test where we got  $p = 0.64 > 0.1$ . This means women begin at a lower level than men, but at the end of the course, they can compensate this situation, at least for the spatial abilities measured by DAT-SR.

## Conclusions and Future Work

Sketch-based applications can provide an effective way of improving spatial abilities and capturing students’ attention. They stimulate students and create a positive attitude to the sketching tasks. The pilot study presented in this paper will serve as a guide for a more ambitious study to be performed at the Polytechnic University of Valencia and Cartagena, Jaume I of Castellón and La Laguna universities during academic year 2005-06.

At the present moment a new sketching tool for helping students to learn dimensioning concepts is being developed. It is based on a research tool developed to manage “parametric” freehand sketches that is going to be adapted for educational purposes.

## Acknowledgements

This work has been supported by the Spanish Ministry of Science and Education and the European Union (Project DPI2004-01373). Also, this work was partially supported by Fundació Caixa Castelló-Bancaixa under the Universitat Jaume I program for Research Promotion (Project P1-1B2004-02, titled “Gestural interface for the introduction of variational-parametric sketches and for the definition of assembly conditions in the computer-aided design of industrial products”).

## References

- P. Company, et al., "An Optimisation-based Reconstruction Engine for 3D Modelling by Sketching". *Computers & Graphics*, 28 (6), 955-979, 2004.
1. P. Company, et al., "On the Evolution of Geometrical Reconstruction as a Core Technology to Sketch-based Modeling", Proceedings of the 2004 Eurographics Workshop on Sketch-Based Interfaces and Modeling (SBM-04), 97-106. Eurographics Association, 2004.
  2. P. Company, et al., "Educational Software for Teaching Drawing-based Coceptual Design Skills. *Computer Applications in Engineering Education*, 12 (4), 257-268, 2004.
  3. M. Contero, et al., "CIGRO: a Minimal Instruction Set Calligraphic Interface for Sketch-Based Modeling". *Lecture Notes in Computer Science*, 2669, 549-558, 2003.
  4. Visit The Bologna process (Next stop Bergen 2005) web site:  
[http://europa.eu.int/comm/education/policies/educ/bologna/bologna\\_en.html](http://europa.eu.int/comm/education/policies/educ/bologna/bologna_en.html)
  5. Visit Socrates-Erasmus: the European Community programme in the field of higher education web site: <http://europa.eu.int/comm/education> .
  6. Visit European Commission. Education and training web site:  
[http://europa.eu.int/comm/education/programmes/socrates/erasmus/erasmus\\_en.html](http://europa.eu.int/comm/education/programmes/socrates/erasmus/erasmus_en.html)  
.
  7. P. Lourtie, Furthering the Bologna Process. Report to the Ministers of Education of the signatory countries. Prague, May 2001. (Visit web site: [http://www.florence-network.info/lourtie\\_Sorbonne\\_Bologna.htm](http://www.florence-network.info/lourtie_Sorbonne_Bologna.htm)).
  8. A. Chevalier, *Guide du Dessinateur Industriel*. Hachette Technique, Paris, 2003.
  9. E. Chirone, et al., *Disegno Tecnico Industriale 1*. Edizioni il Capitolo. Torino, 1996.
  10. E. Chirone, et al., *Disegno Tecnico Industriale 2*. Edizioni il Capitolo. Torino, 1997.
  11. J. Félez, et al., *Dibujo Industrial*. Ed. Síntesis. Madrid, 2003.
  12. J. Félez, et al., *Fundamentos de Ingeniería Gráfica*. Ed. Síntesis. Madrid, 2003.
  13. G. Bertoline, et al., *Fundamentals of Graphics Communication*. Mc Graw Hill, 4<sup>th</sup> ed., 2005.
  14. K. Holliday-Darr. *Applied Descriptive Geometry*. Delmar Publishers. 1998.
  15. E.S. Ferguson. *Engineering and the Mind's Eye*. MIT Press, Cambridge, Mass., 1992.
  16. D.A. Field, "Education and Training for CAD in the Auto-industry". *Computer-Aided Design*, 36(14), 1431-1437, 2004.
  17. J.H. Mathewson, "Visual-spatial thinking: An aspect of science overlooked by educators", *Science Education*, 83 (1): 33-54, 1999.
  18. C. Leopold, et al., "International Experiences in Developing the Spatial visualization Abilities of Engineering Students", *Journal for Geometry and Graphics*, 5(1), 81-91, 2001.
  19. S.G. Vandenberg, et al.; Mental Rotations, a Group Test of Three-dimensional *Spatial Visualization*. *Perceptual and Motor Skills* 47, 599-604, 1978.
  20. CEEB Special Aptitude Test in Spatial Relations (MCT). Developed by the College Entrance Examination Board, USA 1939.
  21. G.K. Bennet, et al., *Differential Aptitude Tests, Forms S and T*. The Psychological Corporation, New York, 1973.

22. R.T. Duesbury, *et al.*, "Effect of Type of Practice in a Computer-Aided Design Environment in Visualizing Three-Dimensional Objects From Two-Dimensional Orthographic Projections". *Journal of Applied Psychology*, 81 (3), 249-260, 1996.
23. R. Devon, *et al.*, "The Effect of Solid Modeling Software on 3-D Visualization Skills", *Engineering Design Graphics Journal*, 58 (2), 4-11, 1994
24. C. Potter, *et al.*, "Perception, Imagery, Visualization and Engineering Graphics. *European Journal of Engineering Education*, 28 (1), 117-133, 2003.
25. M. Alias, *et al.*, "Effect of Instructions on Spatial Visualisation Ability in Civil Engineering Students". *International Education Journal*, 3 (1), 1-12, 2002.
26. S.W. Crown, "Improving visualization Skills of Engineering Graphics Students Using Simple JavaScript Web Based Games", *Journal of Engineering Education*, July 2001, 347-355.
27. J.L. Mohler, "Using Interactive Multimedia Technologies to Improve Student Understanding of Spatially-Dependent Engineering Concepts". Proceedings of the International Graphicon 2001 Conference on Computer Geometry and Graphics, Nizhny Novgorod, Russia 292-300, 2001.
28. O.J. Mengshoel, *et al.*, "Intelligent Critiquing and Tutoring of Spatial Reasoning Skills", *Artificial Intelligence for Engineering Design, Analysis and Manufacturing*, 10, 235-249, 1996.
29. C. Hubbard, *et al.*, "Visual Reasoning Instructional Software System", *Computers in Education*, 28(4), 237-250, 1997.
30. J.R. Osborn, *et al.*, "An Interface for Interactive Spatial reasoning and Visualization". Proceedings of the SIGCHI Conference on Human Factors in Computing Systems, ACM Press, Monterey, California, United States, 75-82, May 3-7, 1992.
31. M. Alias, *et al.*, "Attitudes towards Sketching and Drawing and the relationship with Spatial Visualisation Ability in Engineering Students. *International Education Journal*, 3 (3), 165-175, 2002.