

# **A Practical Approach to a Cad Implementation on a SME (Small & Medium Enterprise)**

Manuel Contero, Pedro Company and Nuria Aleixos

*Departamento de Tecnología, Universitat Jaume I  
Campus del Riu Sec - E12071 Castellón Spain  
e-mail: contero@tec.uji.es*

## **Abstract**

This paper presents a methodology to be used to implement a complex 3D CAD system (as PTC's Pro/ENGINEER) in an automotive sector subsidiary company of the 'Comunidad Valenciana' (Spain). It is believed that such a methodology is needed because the transition from classic "design-by-drawing" methodology to full CAD methodology is rather complex. In other words, managing large assemblies or complex parts just can be done with a wise modelling approach.

Three steps have been considered in our approach:

- Strategies to create part models;
- Strategies to organise the assemblies, and
- Strategies to unify and simplify the management of the whole design process.

In this paper, some general ideas of those strategies will be summarised. Nevertheless, we will focus on part modelling.

## **1. INTRODUCTION**

The low technological profile of many SMEs at Spain, suppose a big problem when compare them with other higher competitors or from other countries. Competitiveness can be improved in many different ways. One of them is raising the technological level of the enterprise, using more advanced tools, like 3D CAD systems. But the available commercial software have reached such a complexity that few SMEs decide to change from the old design philosophies to new tools and methods; for example from 2D design to solid modelling. The reasons of this barrier to change could be resumed in critical elements like: inability to quantify return on investment, lack of qualified personnel, problems of information interchange, previous failures and unknown information of implementing process.

In this context, we are involved in a project titled "Implementing Design and Manufacturing Advanced Technologies in a Concurrent Engineering Environment. Application to an Automotive Components Manufacturing Company" supported by a FEDER-CICYT grant (9I068.01). The principal objective this project proposes is determining

the procedure to follow for a successful implementation of the new technologies and methodologies that support concurrent engineering.

In the first phase of the project, we have to define a methodology to implement a complex 3D CAD system. Our industrial partner in the project wants to make a transition from the 2D-design methodology, using Autocad R14 to a parametric 3D system like PTC's Pro/ENGINEER.

To help us to carry out this objective, we made an Internet search looking for "good practice" documents. Based on these documents [1],[2],[3],[4],[5],[6],[7] and our own experience, we propose some strategies that can be very valuable in an implementation process. Although the following methodology is focused in PTC's Pro/ENGINEER cad system, it can be applied to similar parametric 3D CAD systems.

## **2. STRATEGIES TO CREATE PART MODELS**

Modelling methodology is a little documented topic. Big companies have internal modelling guidelines, because reusing models is an important item due to many applications that take advantage of the solid model, as CAM and CAE software. Also, sharing models among designers, is a difficult question if there is not a common modelling strategy across the enterprise and some documentation rules.

A lot of information is hidden in the solid model. Design intent is important to be explicit; otherwise, model reuse and sharing become difficult or impossible. Modern CAD systems allow the designer name the features or provide notes in order to document their behavior. This is very important, because many times, the parent-child relations between features are difficult to track, and the tools provided to analyze them, are at a very primitive developing stage. Usually, these systems provide some kind of querying tool, to find the parents and children of a feature, but it is difficult to have a whole vision of the interdependencies. A model tree (see figure 1) provides some graphical description of the model structure, but actually it is a historic record of modeling operations, not reflecting the parent-child relations, better represented by a complex graph.

These limitations for understanding the model can produce serious problems when we face the modeling of a complex part. A model with hundreds of features, soon become prone to error when modifications are made. Assuring the quality of models is becoming a very important topic, and one quality indicator is the use of standard design practices to improve the effectiveness of downstream users and design reuse. There are some commercial tools devoted to analyse the modelling rules and control the geometric quality, like Rand Worldwide's ModelCHECK [10], International TechneGroup Incorporated's CAD/IQ [9] and Prescient Technologies's DesignQA [8]. This means that there is a clear need in the industry to define and control the modelling methodology for improving the models quality.

### **2.1. Configuration files and start parts**

Is commonly accepted that modern CAD systems have got high flexibility to address many different design problems, but this flexibility usually implies many configuration options to be established by the user. Certainly, CAD vendors claim to offer default configurations optimised to get a compromise between maximum efficiency and extreme simplicity. Nevertheless, this "homogenisation" may involve a serious penalty on efficiency for advanced users. Consequently, the use of strategies to reconfigure the CAD systems to better fit the particular needs is the first key to maximise efficiency. The CAD system

administrator must do this task because, usually, the CAD users would not be able to alter that, and also it is a complex task, these users are not able to do. With common configurations files, all users will have the same options, default layer structure and datums organisation.

Also it is important noting, that everybody must use the same start parts. Start parts are equivalent to Autocad prototype drawings, or Microstation seed files. Of this way, some items, like the layer structure, default datums and view orientations will be available to all the CAD users, making easier to manage models built by other people.

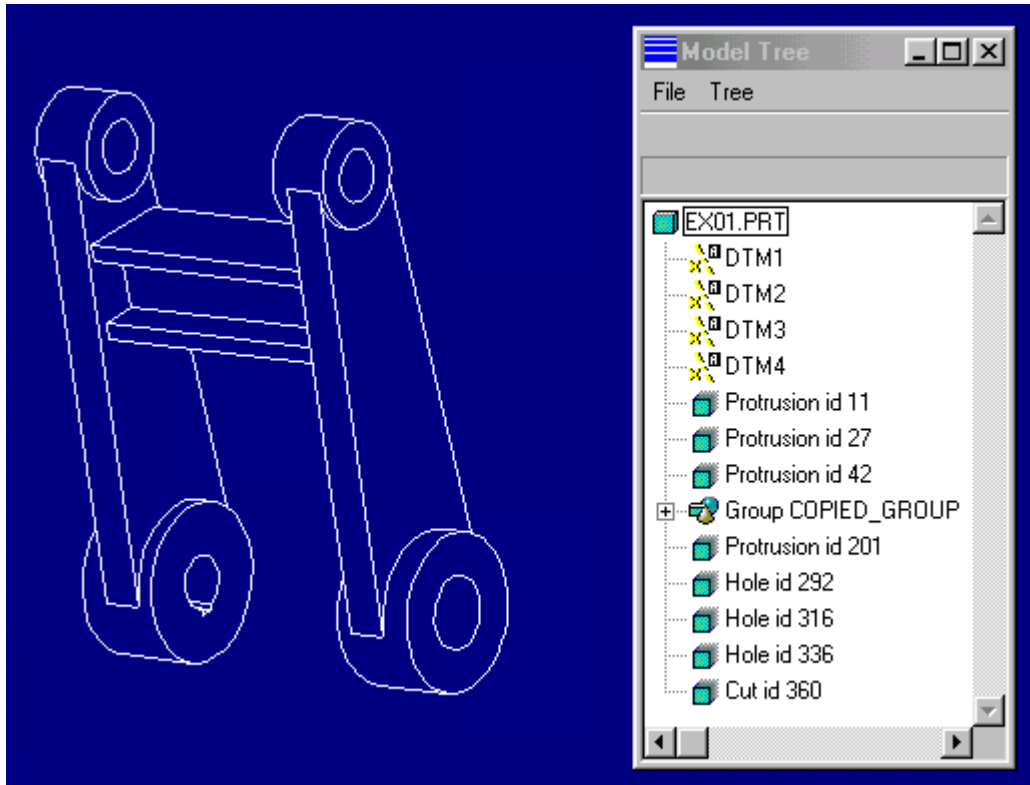

Figure 1. Part and its associated model tree

## 2.2. Datums

PTC's Pro/ENGINEER is a parametric CAD system that heavily uses the concept of datums to drive modelling process. Usually, the default datum planes are the first feature in the model (figure 2). Points, axes, curves and planes can be used as datums that are references for constructing models but they are not geometry features. Their both sides (yellow and red) are used in assembling components, sketching references and orienting views. In Pro/E, you can use datums as items in the model tree or you can make them belong to any feature (also called datums on the fly). The datums on the fly are not shown and selectable, and any dimension related to these datums are just shown with the feature to which they belong. The datum axes are used for making datum planes, for placing items concentrically and for making radial patterns. Axes are also automatically created for features as revolved features and extruded circles and arcs.

Some guidelines are given below to make the best use of Datums in Pro/E:

- To avoid a stackup or undesirable relations in the part model, you should relate datums back to principle datums.
- To avoid clutter on the screen you can use datums on the fly for cross-sectional datums.
- In the case you use datums on the fly to create a pattern, be aware of pattern options can only be chosen if the angle of offset and plane datum constraints are chosen.
- It is recommended to rename datums to make easier their selection by menu and the understanding by other users.

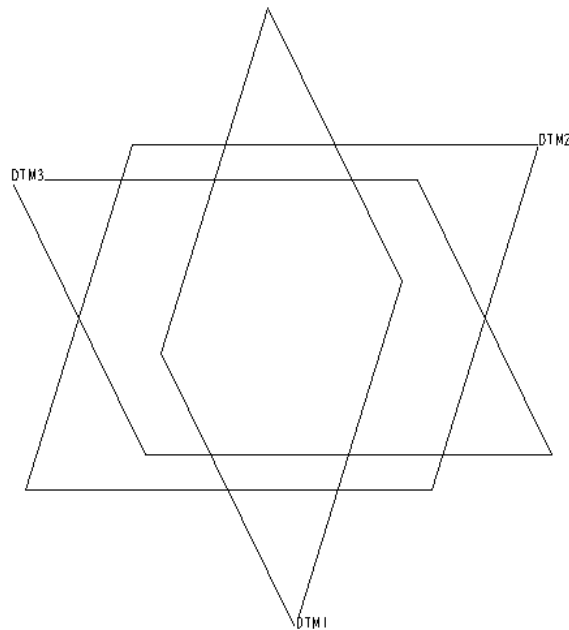

Figure 2. Default datum planes

### 2.3. Creating Parts

In this section, we will consider the best use of the sketcher and some critical aspects of model part creation. The sketcher is the kernel of geometry creation in Pro/ENGINEER. So, there are some critical aspects to take into account. These aspects have to do with the definition of the sketch and orientation planes, and dimensions and alignments to existing geometry. Making the wrong selection of any of the earlier aspects can strongly affect the feature flexibility, parent/child relations and robustness. But you can make a good use of the sketcher following the next recommendations.

- The use of a dimension scheme will make the sketch meaningful; as required on the final drawing where shown dimensions can be used. You should also avoid dimensioning to unrelated features and sketcher relations to make it more flexible and independent.

- Keeping sketches simple will allow you to make operations such as modification and regeneration (more simple sketches better than a complex one) easier. Even with simple sketches you will reduce the risk of failure during modification. You also can make sketches simple by creating the feature in a different way. Later, you can make complex sketches from simple ones if you want.
- To align the sketch is very useful the 3D view to select alignment edges, especially when they are coincident in 2D view. Be sure you do not create undesirable relationships by choosing alignments, and you are recommended to use the preset ones if you can.
- The rounds and chamfers creation is not advisable within sketcher. Their use make hard their later suppression for analysis, may be difficult to modify the sketch without affecting other features in the part and intersecting rounds may not behave correctly.

The most important things to take into account when creating parts are the control of parent/child relations, the control of the external references and the use of a dimension scheme that represents the design intent. If you ignore these three aspects the part can become inflexible and very hard to modify.

- For sketching planes the first choice should be the default datums unless this conflicts with the design intent. Also the new datums should be related back to principle datums to avoid stackup and undesirable relations. Do not create major datums from part surfaces, but from default datums. Use datums planes to reference features and avoid using small features such as fillets, holes, rounds, etc. as references. If references other than datums must be used, reference features to the fundamental geometry. This will avoid complex parent/child relations, which create problems when these small features are suppressed or deleted for analysis.
- Regarding to the parent/child relations, you should avoid unnecessary and deep ones, this will make easier to modify the part. To remove unwanted parent/child relations use *Reroute*.
- Is very useful to name dimensions used in relations and comment relations for user understanding.
- All the rounds and chamfers you need to create in the part should be added as late as possible in the part model creation. This will reduce the risk of referencing tangential edges and creating a feature that can not be suppressed. You must suppress rounds and chamfers when additional features are created, to avoid referencing them.
- Avoid nested features.
- After the creation of the feature name it for future use and introduce parametric dimensions as relations, tolerances, etc. At this point you can add cosmetic features, geometric dimensioning and tolerancing, notes and material parameters as hardness, density, etc.
- Last task you should do (if you need it) is to organise features on layers.

## 2.4. Layers

The use of a layer convention guide when a design is shared among several people is very useful to allow people to get the control on the model visualisation without losing time

looking for the layer structure, what can become very complex (see figure 3, for an example of complex visualization). Layers allow to group items in the model tree so that operations can be performed on them as a group.

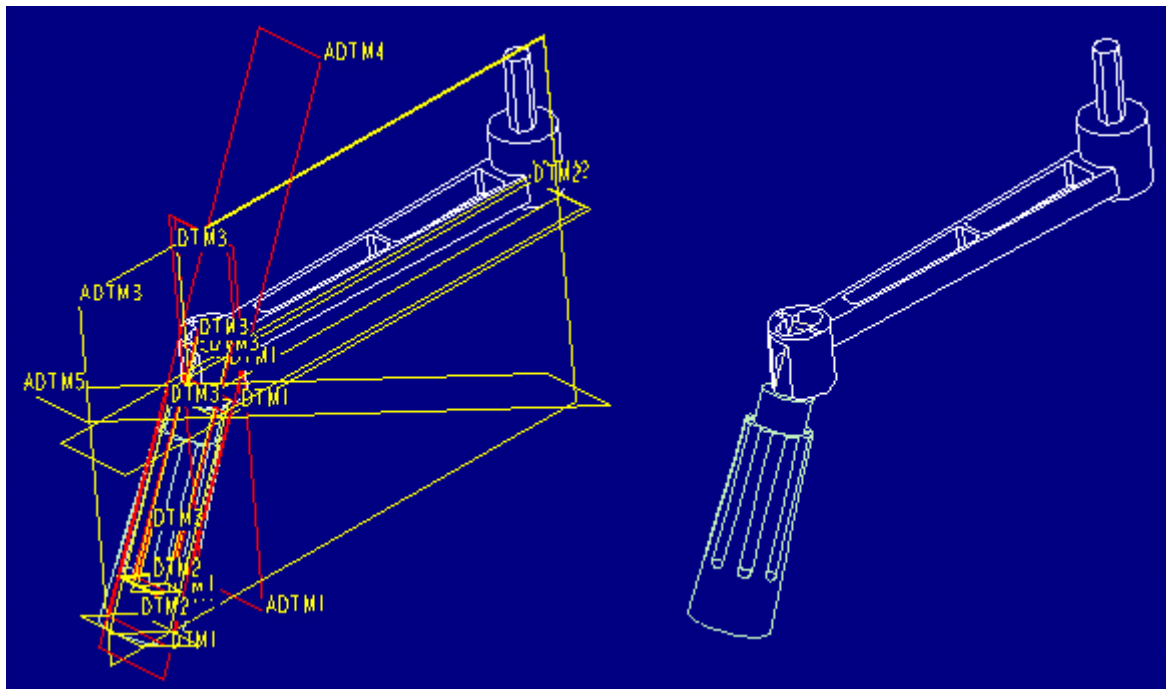

Figure 3. Assembly with or without datum visualization

The configuration file 'config.pro' can define standard layer names, allowing to many items of the design be automatically placed on those layers. The main suggestions we give to work properly with layers in Pro/E are the following:

- The use of the standard layer names speeds up file management time. If no standard layers name exist, you should chose easily recognisable names for other users to understand the design as easy as possible.
- The use of standard layering to share data is an important key to get success in Pro/E. Moreover, the mixture of files using layers and those not using layers causes display problems, mainly in assembly mode.
- Developing a common 'config.pro' file for use across the site will enhance the concurrency among users.
- The use of the primary display controls of layers, BLANK and DISPLAY, causes all items on a selected layer to be "turned off" or to be shown just those items, respectively. As the use of the two controls causes viewing problems, so our recommendation is that you use BLANK control instead of DISPLAY control. If same item is on more than one layer you may have to use DISPLAY to show one or the other.
- You should move some features, as patterns for example, so they can be suppressed for efficiency.

- For improved control you should move miscellaneous datums on their appropriate layers.
- We suggest as well that you place cosmetic features in a particular layer because they are placed automatically in a layer with some other items, and may be you want to control them separately.
- All holes, rounds and chamfers should be placed on their appropriate layer to suppress them for simplification for some analysis.
- The use of nested layers allows controlling several layers at one.
- To layer an item before suppressing it will allow you to resume only those you are interested in by selecting the corresponding layer.
- To suppress several items of the model you can use a common layer to place them. This reduce assembly lag time when some features do not need to be shown in the assembly but are necessary, for example, in the detailing of the part.

### **3. STRATEGIES TO ORGANIZE THE ASSEMBLIES**

Some strategies are given at this point to avoid the more important critical aspects of an assembly in Pro/ENGINEER. These aspects are the control of parent/child relations, the control of the external references and the independence of the parts in an assembly. Ignoring these three aspects can lead to interdependence among parts and assemblies, which can prevent the reuse of engineering data. Some general recommendations are considered below to carry out a proper use of the assemblies in Pro/ENGINEER.

- Avoid creating parts in assembly if possible. Otherwise, use reference viewer to track external references and skeletons to carry shared references.
- Do not use coordinate systems for assembling cause this method is inflexible and does not have any design intent.
- Use skeletons since they are means to share common geometry and to create a framework for component positioning.
- Proper use of layers, allows controlling a complex assembly visualization.

### **4. CONCLUSIONS**

This paper presents an initial work about modelling methodology. Future development will be available at our web site <http://www.tec.uji.es> including guidelines for assembly management and integration with PDM systems. We have noticed that providing a modelling methodology is very useful for people making the transition from classic “design-by-drawing” methodology to 3D parametric CAD. Most CAD vendors provide basic training oriented to learning their systems modelling capabilities, forgiving the importance of a correct modelling strategy. Many times, an implementation support is offered but with an expensive additional cost. It is important remarking that there are many paths conducting to the same geometric model, but only part of them provide a robust basement for downstream applications like CAM and CAE software.

Changing from classic “design-by-drawing” methodology to a solid modelling one requires a strong training plan. Many times, enterprises believe than buying modern workstations and powerful software is enough to assure a successful transition. Both modelling skills and

modelling methodology training are as important as having the right hardware and software tools.

## ACKNOWLEDGEMENTS

The present paper has been realized as part of the research project under the financial support of the Comisión Interministerial de Ciencia y Tecnología (CICYT) and the European Commission (FEDER Programm) (Project 1FD97-0784, titled “Implantación de Tecnologías Avanzadas de Diseño y Fabricación en el Ámbito de la Ingeniería Concurrente. Aplicación a una Empresa de Componentes para Automoción”).

## REFERENCES

- [1] Meier, B., *Pro/ENGINEER Conventions Manual for Integrated Model-Based Design, Analysis and Manufacturing*. TEAM Program Office. P.O. Box 2009, Oak Ridge, Tn 37831-8068. U.S.A.
- [2] Corten, O., *Pro/ENGINEER Tips & Tricks*, <http://utopia.knoware.nl/~ocorten/index.html>
- [3] Turner, I., *Pro/ENGINEER Support Pages*, <http://www.geocities.com/SiliconValley/Orchard/2872/main.htm>
- [4] Spangle, C., *Pro/ENGINEER tutorials, tips, and tricks*, [http://members.home.net/cspangle/Pro\\_Engineer.htm](http://members.home.net/cspangle/Pro_Engineer.htm)
- [5] Anderl, R. and Mendgen R., *Analyzing and Optimizing Constraint-Structures in Complex Parametric CAD Models. Geometric Constraint Solving and Applications*. Springer-Verlag, Germany, 1998
- [6] *Pro/E Newsgroup Graphics Area*, <http://solidsmodeling.com>
- [7] *CADQUEST Tips & Tricks Page* <http://www.cadquest.com/tips.htm>
- [8] Prescient Technologies, <http://www.prescienttech.com/products.html>
- [9] International TechnoGroup Incorporated, <http://www.cadiq.com/>
- [10] Rand Worldwide, <http://www.rand.com/products/software/analysis/modelcheck.html>